

Seal<sup>in</sup>  
TECHNOLOGY

*Integrated Seal as Standard*

**ACO DRAIN® Multiline Seal in Technology Included**



## A Successful Market Player for Over 40 Years

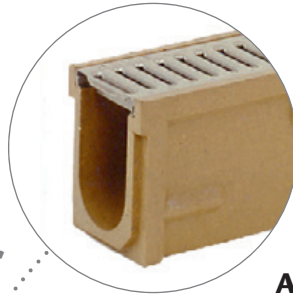

### ACO DRAIN® system N 100

In 1972, the Olympic Stadium in Munich became the first building to be drained by an ACO channel made of **polymer concrete**. Thanks to its outstanding properties, this sustainable material turned out to be truly ground-breaking: it is an ACO innovation which has endured to this very day.



### ACO DRAIN® system N 100 K

Integrated **edge protection** for a better look and **boltless locking**, which makes installation and operation so much easier.

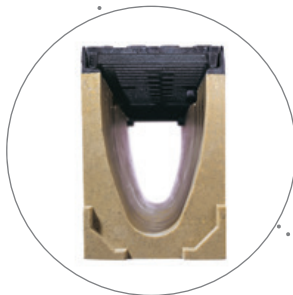

### ACO DRAIN® Multiline

**V-shaped cross** section and a comprehensive, aesthetically-pleasing **range of gratings**: another milestone in the story of ACO DRAIN® line drainage development. ACO Multiline has already proved its worth in millions all over the world.

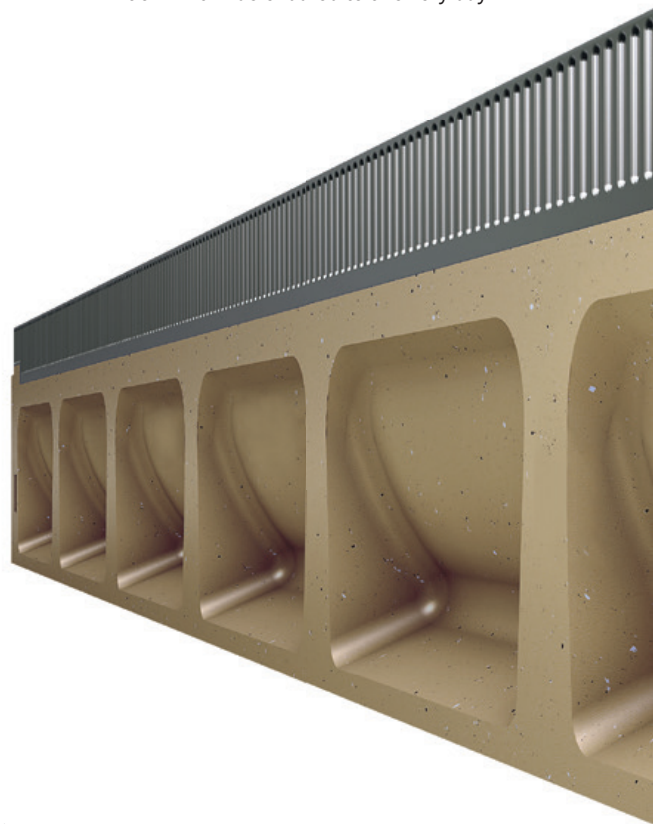
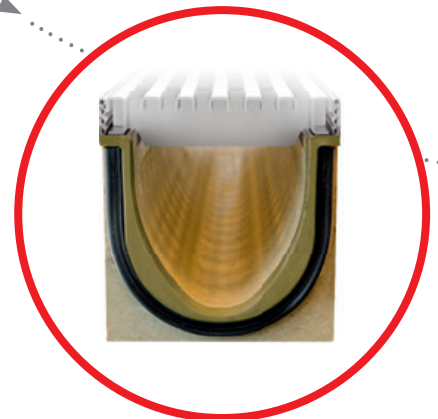

# ACO DRAIN. The Channel.

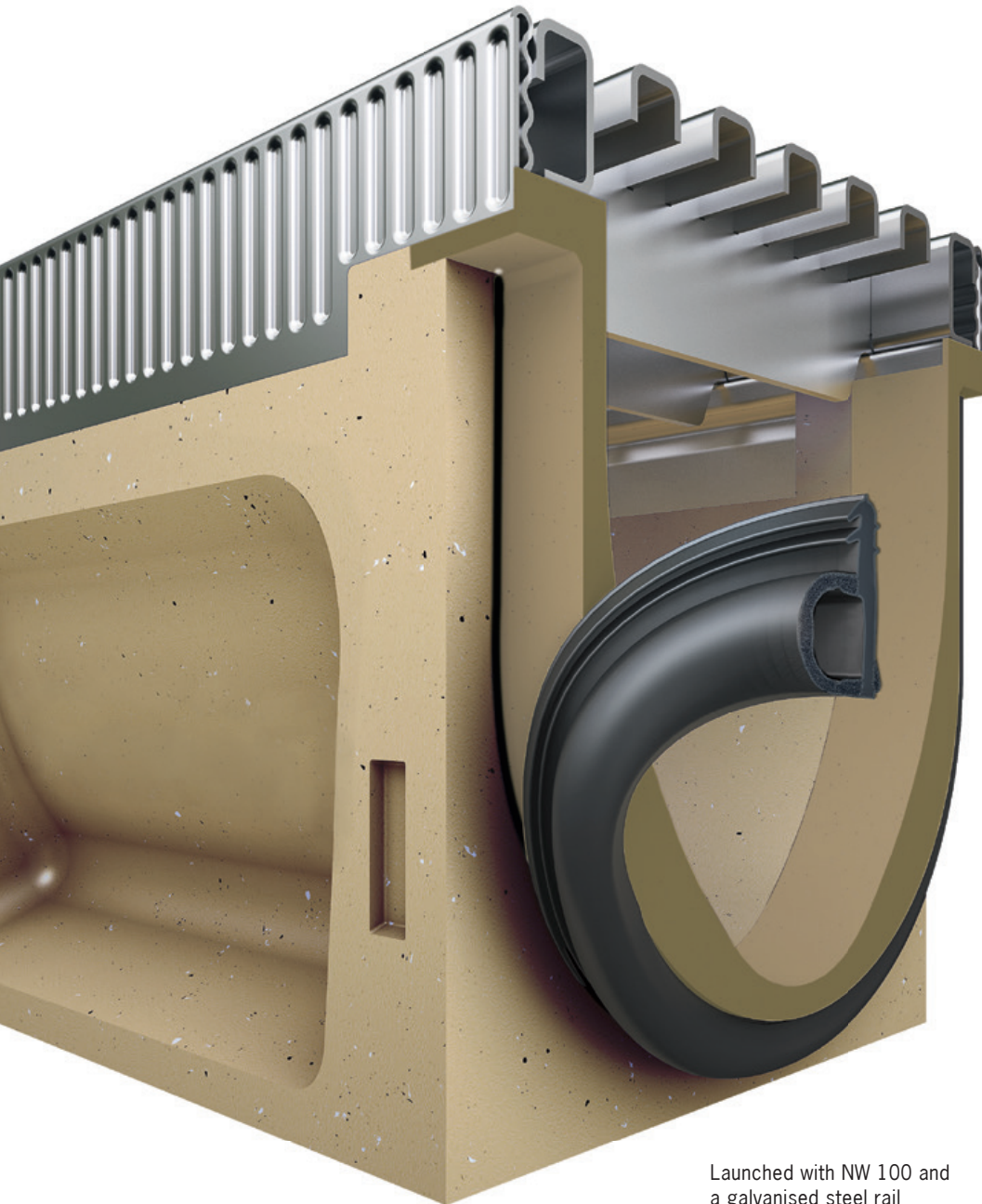

Seal in  
TECHNOLOGY

Other rails and  
nominal widths to follow

Launched with NW 100 and  
a galvanised steel rail

■ 2016

## ACO DRAIN® Multiline Seal in

ACO has always been a pioneer and has always set new standards. Now once again, the company has come up with a real sensation in the channel sector:

this channel, which comes with integrated Seal in technology included, load classes A–E and slope 1–10, brings together the very best features from 40 years of innovation – sealing as standard, easy to install as ever and with excellent performance.

The unique combination of the ACO polymer concrete material on the one hand and sealing on the other creates the very first completely tight channel run that meets the demands of EN 1433. Lots of added value. The new standard of the future from ACO: ACO DRAIN® Multiline Seal in.

## Tightness tested for great reliability

In conventional channel systems, leaking channel joints mean that some water will be lost on its way to the rainwater treatment system; this loss cannot be controlled. But the new ACO channel, however, helps to divert and treat the surface water in a targeted manner.

This is notably confirmed by the long-term test conducted by the IKT, Institute for Underground Infrastructure, with the “IKT-approved” seal.

# Tight\* as Standard

- Tight after 72 hours
- Targeted rainwater management
- Long-term structural protection
- Reliable groundwater protection

Start .....▶ tight after 30 minutes: .....  
standard-compliant

### Proven standard-compliant quality

It goes without saying that the new channel system meets the current product requirements of the latest industry standards DIN EN 1433/DIN 19580. Two independent testing institutes from both Germany and the United Kingdom have confirmed this through successful type testing for the load classes A 15–E 600. All relevant test criteria were met and documented.



Institute for Materials Testing,  
Bremen



The British Standards Institution,  
London

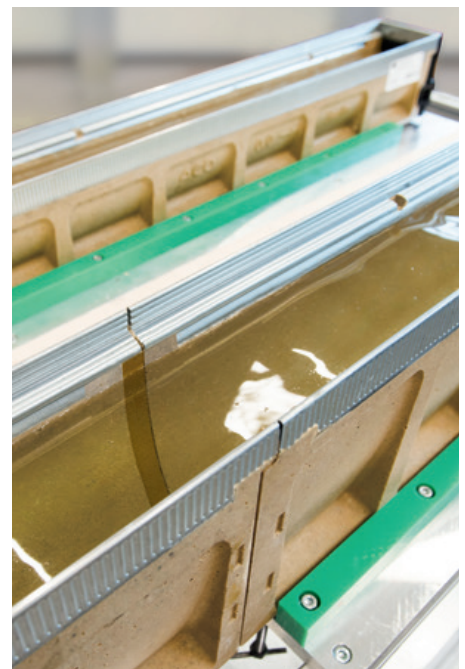

Tightness test

# Simple to Install

- Easy readjustment from above
- Lightweight
- Simple push-in system
- No additional working process

# Permanently Resistant

- Tight following long-term simulation (500,000 load cycles)
- Waterproof materials such as ACO polymer concrete and modern synthetic materials
- Integrated EPDM seal



IKT – Institute for Underground Infrastructure, Gelsenkirchen, Germany

tight after 72 hours:  
exceeded standard



Tightness testing after long-term simulation

## \* What does "tight" mean?

According to DIN EN 1433/DIN 19580, Section 9.3.6, the tightness test must show that, when wet, the cross section provided by the design in question remains waterproof for 30 minutes ± 30 seconds. This compliance with the tightness requirements is surpassed many times over by the Multiline with Seal in technology as standard, as shown by the IKT approval seal D00978. The test confirms sustained tightness over 72 hours after 500,000 load cycles. The load cycles simulate the conditions experienced by the channel connections after being travelled over for many years.

Tightness over 72 hours was successfully proven for the entire system, including all accessories such as inlet shafts and end caps. The IKT also confirms the usual simple installation – nothing about the tried-and-tested assembly from above will change.

Whenever we refer to "tightness", "tight" and "waterproof" in this brochure, it is always in the sense of meeting waterproof demands according to DIN EN 1433/DIN 19580, Section 9.3.6, and the IFT certificate specified above.

# Controlled Rainwater Management

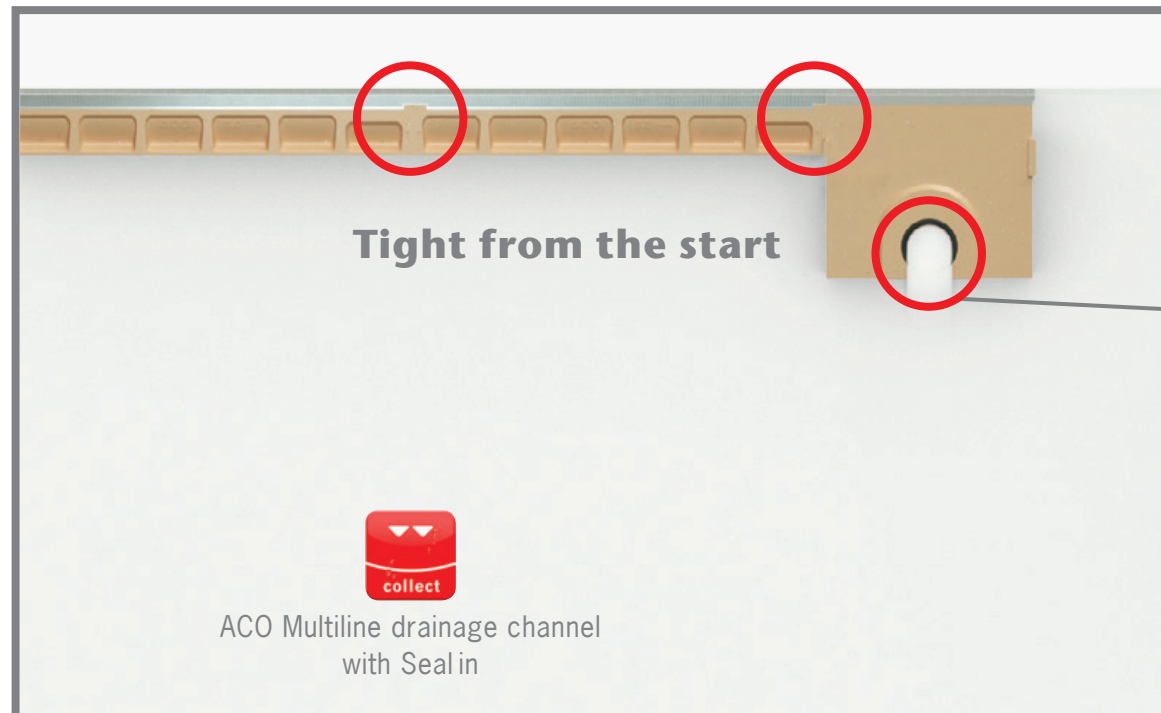

## All along the ACO system chain, no drop is lost

ACO Multiline is the channel equipped with integrated seal as standard.

With its Seal in technology, ACO reliably seals the key points in any line drainage system, so when it comes to tightness and water quality, ACO Multiline is able to meet tomorrow's demands, today.

### **Tightness of the channel train**

The IKT (Institute for Underground Infrastructure, based in Gelsenkirchen, Germany) has carried out comprehensive testing that verifies the tightness of the ACO DRAIN® Multiline Seal in; the product has been certified by the Institute too (see Page 4 ff.). Alongside the ACO polymer concrete material, another essential element of the Seal in technology is the newly

developed captive two-component seal. The channel body is also produced using a special two-component method. This results in a tight channel run, so the surface water collected is all routed into the ACO system chain, with no losses. This targeted system of rainwater management ensures that the structure and groundwater are protected in the long term.

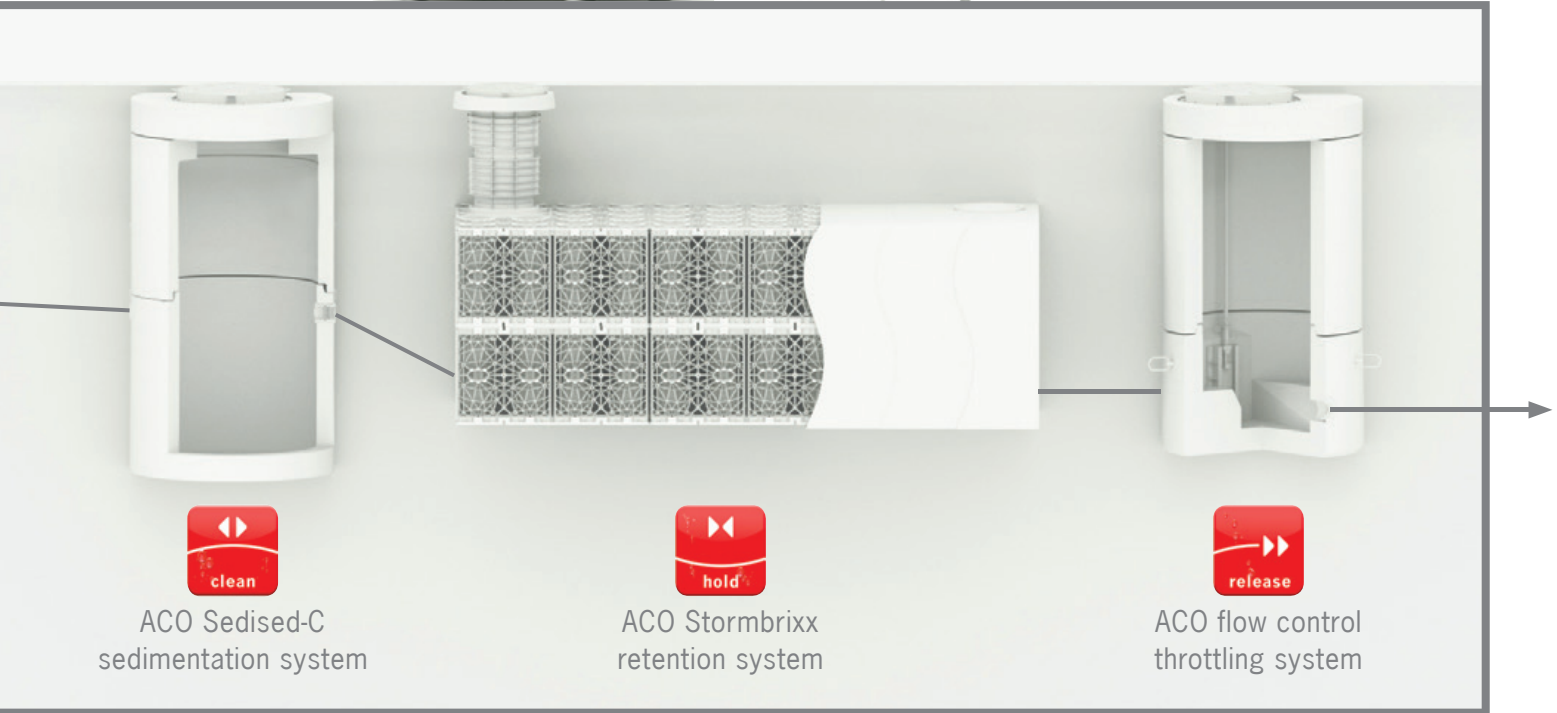

**collect:**

Gather and capture

**clean:**

Pre-treat and process

**hold:**

Contain and retain

**release:**

Pumping, discharging and reusing



**Example application**

ACO system chain for retaining rainwater using ACO Stormbrixx:

**Rainwater** is collected by the ACO Multiline drainage channel with Seal in technology included

**Rainwater** is cleaned by the ACO Sedised-C sedimentation system

**Rainwater is temporarily** stored in the ACO Stormbrixx infiltration system

**Rainwater is released** in a controlled manner via an ACO flow control

## For a clean and targeted rainwater cycle

Advisory Leaflet DWA – M 153 "Recommended Actions for Dealing with Storm Water" from the German Association for Water contains directives on how to evaluate and treat rainwater run-off. The quality assessment will determine what treatment the rainwater requires. The process of evaluating the run-off load for different areas of land takes airborne factors and surface contamination into account, before coming up with appropriate measures.

### Never waste usable rainwater

Experience has shown that the permissible water score is soon reached, with the run-off load being too high as a result. This means that the rainwater which is running off must be pre-cleaned. With the new ACO DRAIN® Multiline Seal in channel, which comes with integrated seal as standard, ACO is therefore helping to achieve a targeted, controlled and planning-compliant system of rainwater management. This ensures that none of the rainwater can be uncontrollably lost into the soil on its way to the rainwater treatment system.



Prof. Dr.-Ing. Bert Bosseler  
IKT – Institute for Underground Infrastructure, Gelsenkirchen, Germany

### “Collect and treat polluted surface water safely.”

“Increasing the ability to adapt to the adverse impacts of climate change” is, according to Article 2 of the UN Paris Agreement, a goal of equal rank to the restriction of global warming to 2°C. This comes at a time when urbanisation is increasing, more and more areas are becoming sealed, pollutant contamination is rising and the demands placed on water quality are growing. Local authorities are therefore faced with this great challenge – having to deal with increasing amounts of surface water as well as collecting and treating large proportions of polluted rainwater. There is a demand for new concepts and innovative system technology in

order to carry out these duties at a justifiable economic cost. Key words include inundation areas, decentralised and semi-centralised treatment as well as new systems for drainage and temporary storage. Naturally, the surface water which is to be treated has to reach the treatment plant safely, i.e. the relevant drainage systems must not only be stable and reliable, but also watertight throughout their operating life. Innovative product suppliers are already taking these demands into consideration, and are having their successful developments tested by neutral and independent institutes.



**"Draining away contaminated waste water reliably protects the quality of the groundwater – in particular where local infiltration is concerned."**

In a time when we are becoming increasingly sensitive to environmental impacts and to the knowledge that groundwater is an important resource which must be protected, I think it is vital for us to develop tight drainage channels – indeed, it is high time that we did so. Alongside yard drains and road gullies, which we have been able to produce tight versions of for quite some time now, linear drainage installations have to meet really high standards in terms of design. As a landscape architect, different types of manhole covers and various lighting options enable me to respond to the many and varied planning demands with which I am faced.

It is becoming increasingly more common to see stipulations demanding the infiltration of surface water. Infiltration installations often have to be accommodated locally, as the surfaces available in urban areas are getting ever more scarce. Here in particular, it is incredibly important to be able to drain away contaminated waste water in a controlled manner. A waterproof channel protects the entire structure, which will have a concrete base in line with technical requirements; otherwise, escaping water would often have a destructive effect here due to the action of frost. As a result, the lifetime of the "drainage channel" structure is extended considerably: so, waterproof channels have a part to play in sustainable construction.



Wolfram Munder  
Dipl.-Ing. Landscape architect at bdla,  
Hamburg/Bochum, Germany



Dr Volker Brandt  
Managing Director of Stahlbeton- und  
Tiefbau GmbH & Co. KG, Westerrönfeld,  
Germany

**"Permanently protected structures"**

As civil engineers, we are familiar with the installation of drainage channels. Due to their lightweight nature, ACO DRAIN® polymer concrete drainage channels are the top choice for our projects. We were initially sceptical about the new ACO DRAIN® Multiline Seal in with sealing, as we feared there would be additional installation costs. However, this was all put into perspective once we had used the solution. We are

familiar with having to grease the sealing when laying our drainage lines. This new approach by ACO, to equip drainage channels with sealing as standard, leads to a permanently protected structure. For us as a construction company, it is of course a strong argument throughout the installation of drainage channels vis-à-vis building owners in terms of protecting the environment.

**"With the new Multiline Seal in, we will be able to fulfil future market demands."**

ACO Tiefbau has been the top partner of team baucenter for many years in the field of drainage technology for civil engineering, road construction and landscaping. Throughout the years of collaboration we have regularly supported the market launch of new ACO products. As regional market-leading merchants of building materials, we will be equally supportive of Multiline Seal in, as we share ACO's aspiration to always offer our customers the latest products. The topic of tightness testing in water protection areas and land drainage systems has also been a hot topic in

Schleswig-Holstein. From our point of view, it is therefore only right that ACO is the first supplier to also introduce the technical feature "tight" with respect to drainage channels. Working together with ACO with respect to the storage and distribution of the new channels, we will be able to meet future market demands. Through coordinated pre-sales amongst our shared target groups, the market changeover from the old Multiline to the new Multiline Seal in will be carried out successfully.



Dirk Kobrock  
Site manager of team baucenter  
civil engineering, Kiel, Germany

Contamination by traces of ...

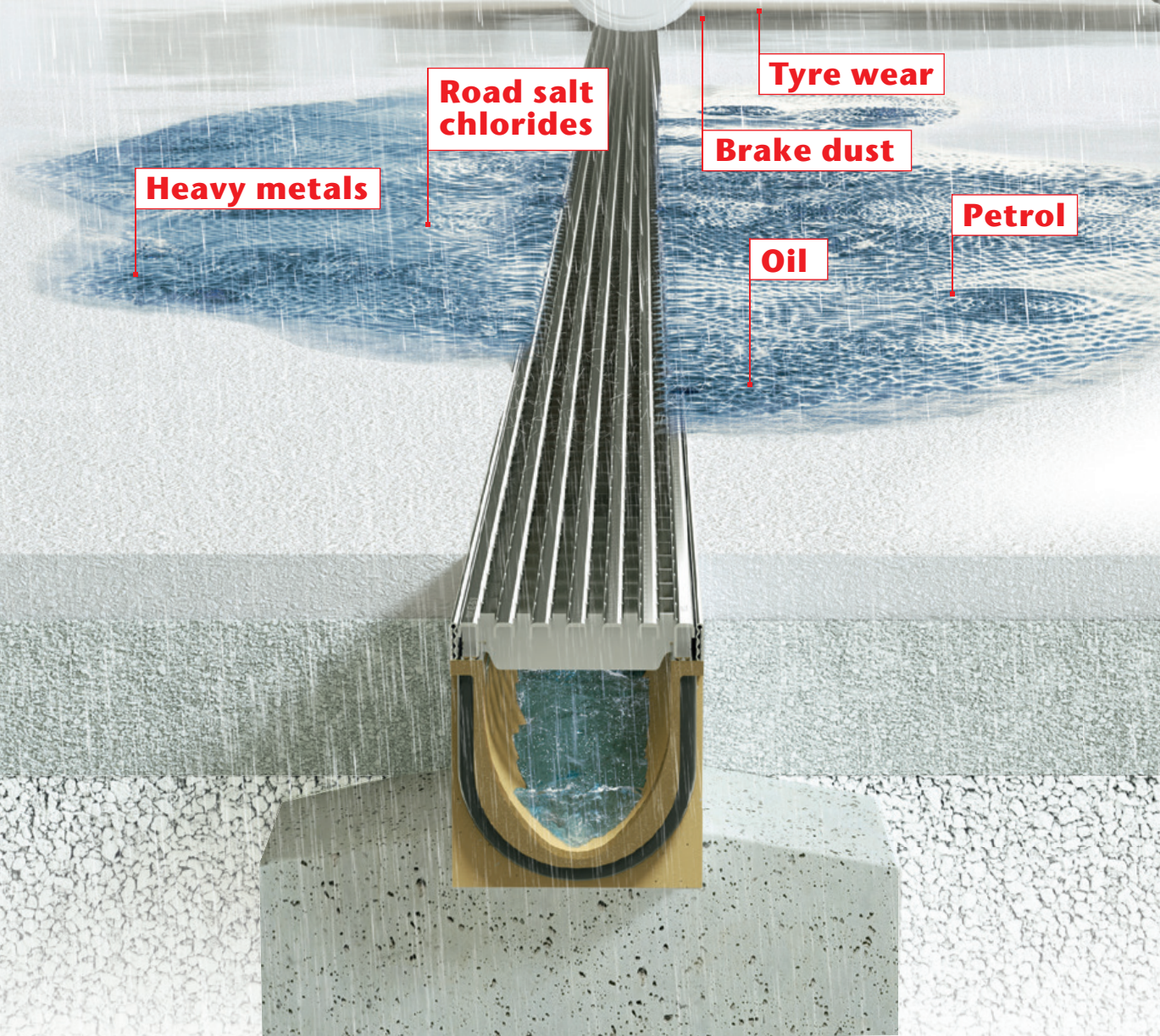



# Groundwater Protection

Recommended actions stipulate how to deal with rainwater on both public and private surfaces. The tightness of drainage is becoming more and more important in this regard.

Soot

Sediments

# Structural Protection

Most structures are built on solid concrete foundations; these should be protected against the effect of chlorides in order to prevent corrosion and an associated weakening of the foundations.

## Preventing irreversible damage early on

Rainwater that runs off from traffic areas often contains lots more impurities than one would expect: heavily frequented roads are exposed to harmful substances from tyres (wear), brake dust and exhaust emissions, as well as traces of petrol and oil. That's not to mention de-icing products used during the winter months. When it rains, all these impurities are inevitably washed into structures and groundwater, where they can cause considerable damage. For example, the chlorides present in road salt can lead to corrosion and a weakening of a building's foundations.

The ACO DRAIN® Multiline Seal in drainage channel, which is equipped with integrated seal as standard, collects the water and feeds it to the rainwater treatment system, then finally into the natural rainwater cycle, without any avoidable loss. As such, it plays a crucial part in reliably collecting and diverting impure surface water. It is therefore possible to minimise irreversible damage caused to structures, the weakening of concrete foundations and the load to which groundwater is subjected from the very start.

**Forward-looking innovation –  
a detailed look at Seal in technology**

**Seal in**  
TECHNOLOGY

# Tight Channel Run

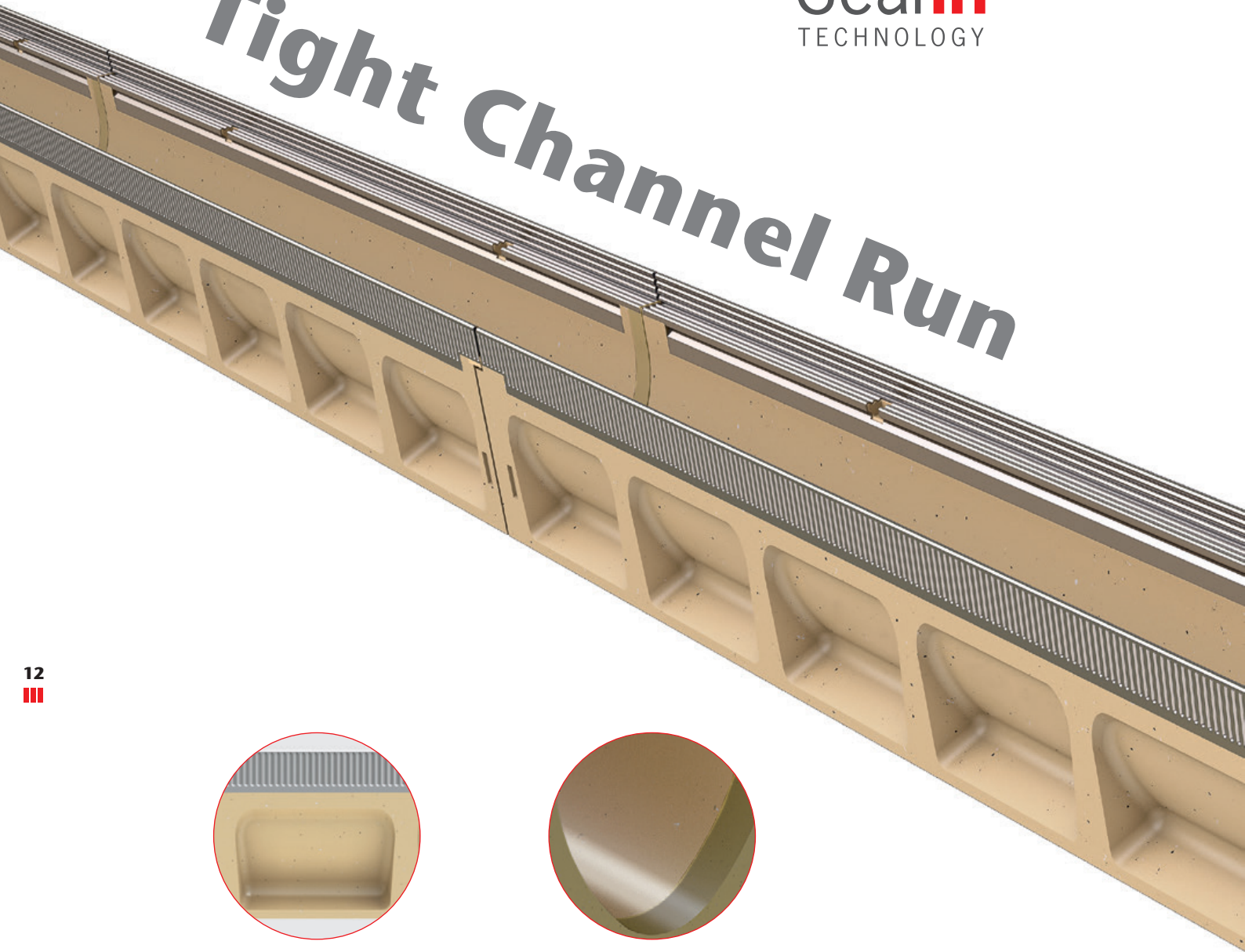

12  
■■■



### **Robust channel body**

The improved geometry makes the channel body more robust, as reflected in optimised installation recommendations that are appropriate to the application. It has now been possible to reduce the concrete quality for the foundation concrete to C 12/15 across the board for load classes A–C.

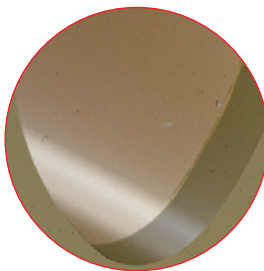

### **Better self-cleaning**

Due to the even transition elements at the channel connection and the smooth surface of the ACO polymer concrete, the channel's self-cleaning function is now even better than it was before.



All product and planning information is only a click away: video clip, product brochure, article description, installation and operation manual, supplementary price list

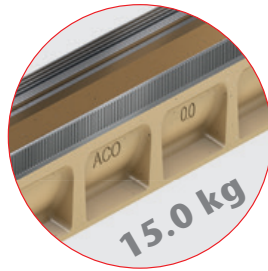

**Tried-and-tested, simple handling**  
ACO polymer concrete products are lighter than concrete products, yet have the same load capacity: a huge advantage when it comes to handling, transport and installation.

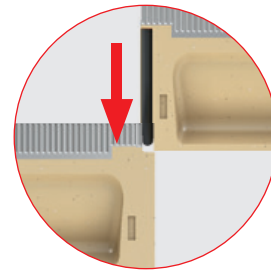

**Easy installation from above**  
The simple and familiar push-in system remains – nothing has changed with the tried-and-tested mounting method.

## = Channel Joint With Seal + Tight Material

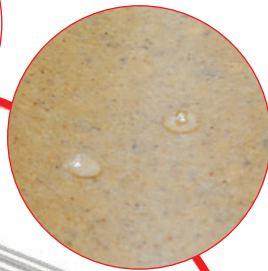
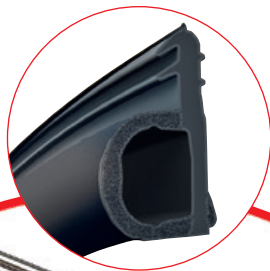

The **EPDM seal, which is integrated as standard**, connects two channel bodies in a way that ensures they are waterproof; see Page 4 ff.  
This technology has been made possible by a patented two-component manufacturing process.  
Thanks to **ACO polymer concrete**, a material with a water penetration depth of 0 mm, the entire channel run is waterproof.

## Versatile gratings for good-looking projects

ACO Multiline Seal in can be combined with all Drainlock gratings, so there is a huge range of gratings available in lots of different shapes, colours and materials – cast iron or stainless steel, hot-dip galvanised steel or plastic. These options are able to meet any and all demands in terms of aesthetics, functionality and load.



### Mesh grating Q+

Steel, galvanised  
Stainless steel



[www.draindesign.de](http://www.draindesign.de)

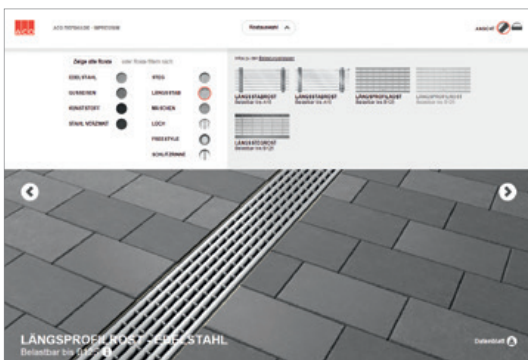

### The complete grating range in the Grating Configurator

You will find all the technical details relating to the new ACO DRAIN® Multiline Seal in channel system, as well as the full range of gratings, in the supplementary price list and the Grating Configurator. The Configurator enables you to choose gratings by viewing them in different scenarios. You can download technical information or save it to the property file.

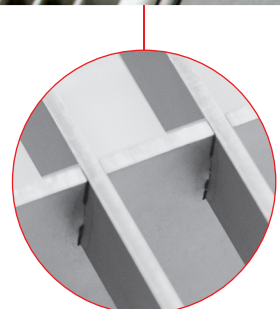

# Highlights From the A-E Range of Gratings



**Longitudinal bar grating**  
Stainless steel



**Longitudinal profile grating**  
Steel, galvanised  
Stainless steel



**Composite grating with microgrip**  
Anti-slip plastic

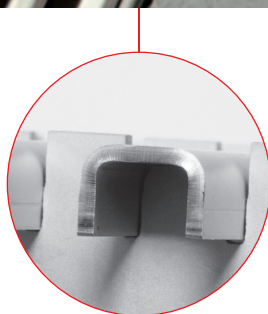
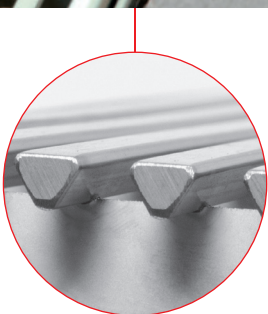

**Hydraulics:** optimised intake area  
**Heelguard:** slot width max. 10 mm  
**Non-slip:** according to DIN 51130, min. R 11



**Every product from ACO Tiefbau contributes to the ACO system chain**

- Drainage channels
- Road gullies and yard drains
- Gully tops
- Manhole covers
- Separators
- Backup systems
- Rainwater treatment
- Pumping stations
- Tree grids
- Amphibian conservation



**For further information, refer to our supplementary price list. Download package available from [www.aco-tiefbau.de/sealin](http://www.aco-tiefbau.de/sealin)**

**ACO Tiefbau Vertrieb GmbH**

PO Box 320  
24755 Rendsburg  
Germany  
Am Ahlmannkai  
24782 Büdelsdorf  
Germany  
Tel. +49 (0) 4331 354-500  
Fax +49 (0) 4331 354-358

PO Box 1125  
97661 Bad Kissingen  
Germany  
Neuwirtshauser Strasse 14  
97723 Oberthulba  
Germany  
Tel. +49 (0) 9736 41-50  
Fax +49 (0) 9736 41-21

[tiefbau@aco.com](mailto:tiefbau@aco.com)  
[www.aco-tiefbau.de](http://www.aco-tiefbau.de)